

SPECIFICATIONS

2-HOUR VERTICAL LETTER FILES



FIREPROOF INSULATION is Thermocell II, reinforced by a 1" by 2" lattice made of 14-gauge galvanized welded steel wire, providing complete peace of mind from fire, impact, or explosion.

FIELD REPLACEABLE STEEL PANELS can easily be replaced in the event that any panel is damaged.

FINISH is an environmentally-friendly electrostatic powder coating applied to all sides, including bottom. The finish is scratch-resistant, providing a lifetime quality appearance. Standard colors available include: parchment, tan, taupe, brown, black, sand, champagne, platinum, and pewter.

DRAWER BODIES are built with high sides for use with hanging folders – no additional frames are needed. Each file includes 1 follower block and one hanging folder frame per drawer.

DRAWER SUSPENSIONS are maintenance free.

DRAWER LOCKS are UL®-listed Medeco high-security key locks.

DRAWER PULLS are surface mounted to allow for extra insulation inside the drawer heads.

INSULATION BETWEEN ALL DRAWERS makes each drawer a separate insulated container.

WATER RESISTANCE means files are designed to prevent water damage resulting from sprinklers and fire hoses.

2-POSITION DRAWER CATCH allows access to certain drawers while others remain locked.

DRAWER HEADS are formed of welded steel and filled with fireproof insulation, and are field replaceable.

UNDERWRITERS LABORATORIES® (UL®) FIRE & IMPACT RATING on all file cabinets. These models carry the 2-Hour Class 350 Fire with Impact UL label. Tests include 2 hour exterior fire exposure at 1850°F, a 2000°F explosion test, and a 30 foot drop to test impact integrity.

OPTIONAL UPGRADES are available to enhance your file's appearance or functionality.

Upgrades available include custom color finishes, standard lock options, casters, and interior options such as document inserts, trays, and inner drawers.

FIREKING'S 3-YEAR LIMITED WARRANTY includes parts and labor provided by a factory authorized technician. Beyond the base warranty, if your FireKing file is ever required to protect your documents in a fire and its protective properties are damaged, FireKing will replace the file free of charge.

Filing Arrangement:

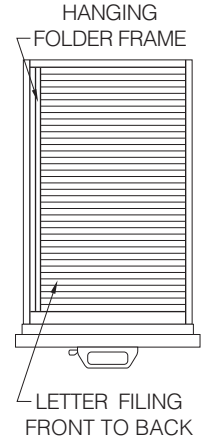

SIDE VIEW:

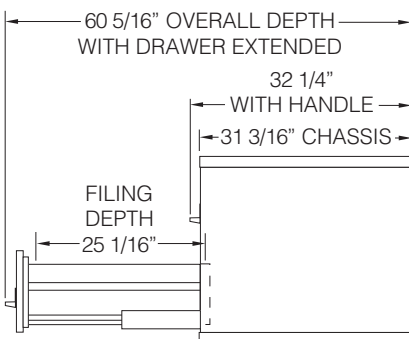

MODEL 2-1929-2:

482 lbs (avg. ship wt.)

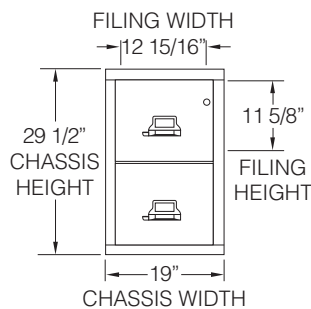

MODEL 3-1943-2:

674 lbs (avg. ship wt.)

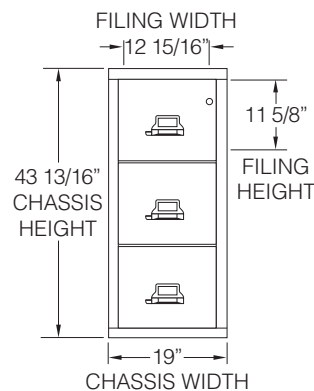

MODEL 4-1956-2:

957 lbs (avg. ship wt.)

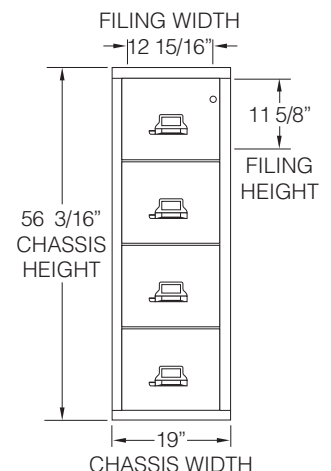

Dimensions
±1/16 inch



FireKing Security Group
101 Security Pkwy • New Albany IN 47150
800.457.2424 / 812.948.8400
www.fireking.com