

BATTERY LOW WARNING

- Repeated beeping during an opening indicates that the battery is low and needs immediate replacement.
- Uses either one (1) 9-Volt Alkaline Battery or six (6) "C" cell batteries. LA GARD recommends the use of Duracell™ or Eveready™ Alkaline batteries. LA GARD recommends the replacement of batteries at least once annually.
- **If internal battery is depleted and will not allow lock to open, hold a new 9-volt alkaline battery on the contact points (large battery terminal to large keypad contact, small to small) located on the front of the keypad. Maintain contact, enter and valid code and turn keypad to open lock. Change battery(s) as directed below. Lock contains a non-volatile memory, even with batteries removed the lock will retain all programming.**

NOTE: You must maintain battery contact at all times throughout the entire procedure.

CHANGING YOUR BATTERY

- ① Open safe door.
- ② Remove battery box cover by pulling the front portion away from the safe door.
- ③ The connector is easily removed by unsnapping it from the two terminals on the top of the battery.
Never Pull on the Battery Leads
- ④ Connect a new 9-Volt Alkaline battery to the battery clip.
- ⑤ Push the battery and the leads completely up into the battery compartment.
- ⑥ Replace the cover and test the unit several times before closing the door

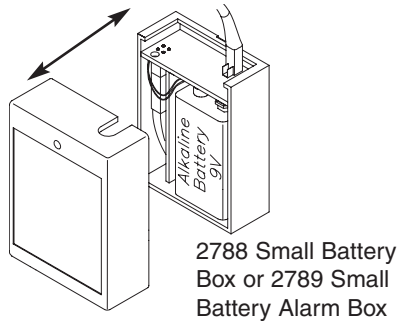

CHANGING YOUR BATTERY

- ① Open safe door.
- ② Remove battery box cover by pulling the front portion away from the safe door.
- ③ Remove six "C" cell batteries.
- ④ Insert six new "C" cell batteries
- ⑤ Replace the cover and test the unit several times before closing the door.

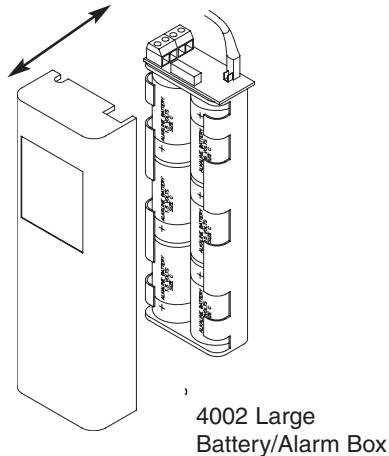

COMBOGARD

3035 Electronic Entry Device

USER OPERATING INSTRUCTIONS

Please see Manager Instructions for additional features that may be activated on your unit.

FEATURES

USER CODE

- Open Lock
- Change Code

WRONG TRY PENALTY

- Four (4) consecutive invalid codes initiates five-minute delay period.

LOW BATTERY WARNING

- Repeated audio and visual signal (LED flashing and repeated beeping) during opening indicates battery low.

AUDIO AND VISUAL SIGNAL

- Double signal (LED flashes and unit beeps) indicates entry is valid or accepted.
- Triple signal indicates invalid or not accepted.

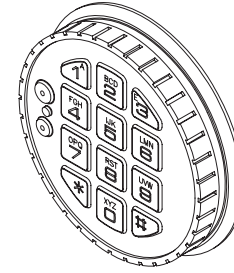

OPENING THE LOCK

- ① Enter valid six (6) digit code.
 - ② The lock will indicate a valid code entry with a double signal.
 - ③ Within four (4) seconds, turn keypad to open position. (Clock-wise)
 - ④ Pull door open.
- **Invalid Code Entry** - Lock will signal three (3) times.

WRONG TRY PENALTY

- Entry of four (4) consecutive invalid codes starts a 5-minute delay period.
 - LED flashes red at ten (10) second intervals.
- At the end of the delay period, two more consecutive invalid codes will restart an additional 5-minute delay period.

Entry will not respond to a single keystroke during delay period.

CHANGING YOUR CODE

ALWAYS PERFORM THIS OPERATION WITH THE DOOR OPEN

- ① Enter "zero" six times.
 - ② Enter your existing six (6) digit code one time.
 - ③ Enter your NEW six (6) digit code two times.
 - ④ If a mistake is made wait thirty (30) seconds and repeat steps ① - ③.
 - ⑤ Test lock operation several times before closing the door.
- **Valid Code Entry** - Double signal after valid six (6) digit code is entered.
 - **Invalid Code Entry** - Triple signal and old code is still valid.